

# FIELDKING

## Termivator Rotary Tiller

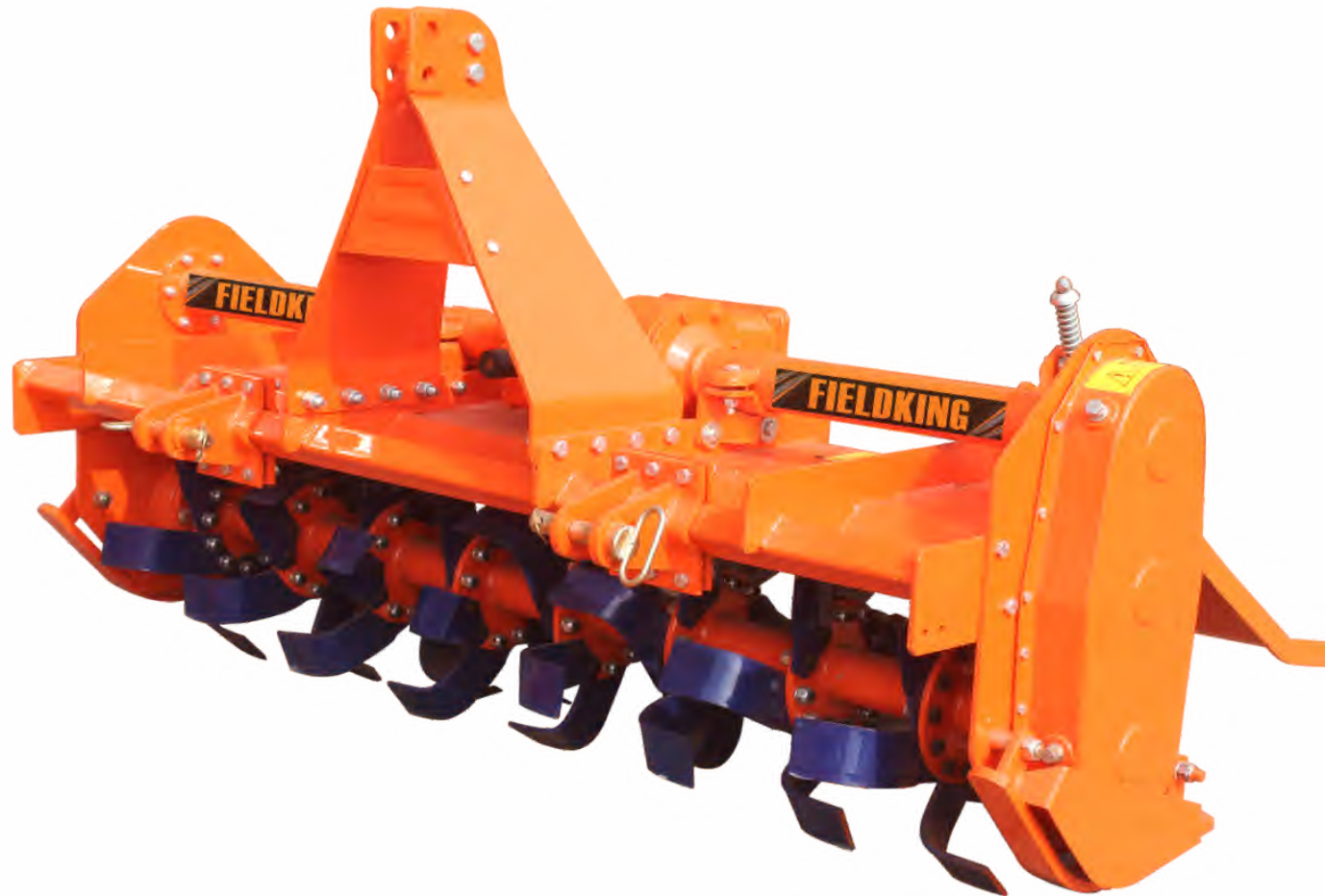

➤ [Operator Manual](#) ➤ [Service Manual](#) ➤ [Part Catalogue](#)

# CONGRATULATIONS!

You have invested in one of the best implements of its type in the market today.

The care you give your "FIELDKING" implement will greatly determine your satisfaction with its performance and its service life. A careful study of this manual will give you a thorough understanding of your new implement before operating.

If your manual is lost or destroyed, "FIELDKING" will be glad to provide you a new copy. Visit to nearest dealership & get a copy. Most of our manuals can also be downloaded from our website at [www.fieldking.com](http://www.fieldking.com).

As an authorized "FIELDKING" dealer, we stock genuine "FIELDKING" parts which are manufactured with the same precision and skill as our original equipment. Our trained service persons are well informed on methods required to service "FIELDKING" equipments and are ready to help you.

Should you require additional information or assistance, please contact us.

YOUR AUTHORIZED

FIELDKING DEALER

BECAUSE "FIELDKING" MAINTAINS AN ONGOING PROGRAMME OF PRODUCT IMPROVEMENT, WE RESERVE THE RIGHT TO MAKE IMPROVEMENTS IN DESIGN OR CHANGE IN SPECIFICATION WITHOUT INCURRING ANY OBLIGATION TO INSTALL THEM ON UNITS PREVIOUSLY SOLD. BECAUSE OF THE POSSIBILITY THAT SOME PHOTOGRAPHS IN THIS MANUAL WERE TAKEN OF PROTOTYPE MODELS, PRODUCTION MODELS MAY VARY IN SOME DETAIL. IN ADDITION, SOME PHOTOGRAPHS MAY SHOW SHIELDS REMOVED FOR THE PURPOSE OF CLARITY. NEVER OPERATE THIS IMPLEMENT WITHOUT ALL SHIELDS IN PLACE.

# TO THE PURCHASER

This manual contains valuable information about your new "FIELDKING" Termivator Rotary Tiller. It has been carefully prepared to give you helpful suggestions for operating, adjusting, servicing and ordering spare parts.

Keep this manual in a convenient place for quick and easy reference. Study it carefully. You have purchased a dependable and sturdy Termivator Rotary Tiller but only by proper care and operation you can expect to receive the service and long life designed and built into it.

Sometime in the future your Termivator Rotary Tiller may need new parts to replace which are worn out or broken. If so, go to your dealer and provide him equipment's detail like model and part number.

## CUSTOMER INFORMATION

Name \_\_\_\_\_

Purchased From \_\_\_\_\_

Date of Purchase \_\_\_\_\_

Model No. \_\_\_\_\_

Serial No. \_\_\_\_\_

## PURCHASER / OPERATOR'S RESPONSIBILITY

1. Read and understand the information contained in this manual.
2. Operate, lubricate, assemble and maintain the equipment in accordance with all instructions and safety procedures in this manual.
3. Inspect the equipment and replace or repair any parts that are damaged or worn out which under continued operation would cause damage, wear to other parts, or cause a safety hazard.
4. Return the equipment or parts to the authorized "FIELDKING" dealer, from where it was purchased, for service or replacement of defective parts that are covered by warranty. (The "FIELDKING" Factory may inspect equipment or parts before warranty claims are honored.)
5. All costs incurred by the dealer for traveling to or transporting the equipment for warranty inspection and claims will be borne by the customer.

## INDEX

### 1. TECHNICAL DATA

- 1.1 Introduction
- 1.2 Warning signal
- 1.3 Danger signal
- 1.4 Personal protective equipment
- 1.5 Equipment safety guidelines
- 1.6 Indicator signal
- 1.7 Identification

### 2. SAFETY AND ACCIDENT PREVENTIONS

### 3. INSTRUCTIONS FOR OPERATOR

- 3.1 Machines supplied partly broken-down
- 3.2 Before use
- 3.3 Hitching to the tractor
- 3.4 Cardan shaft
- 3.5 Working depth
- 3.6 Hoe blades
- 3.7 In working
- 3.8 How it works
- 3.9 Troubleshooting hints for the tractor operator
- 3.10 Parking

### 4. MAINTENANCE

- 4.1 Every 8 work hours
- 4.2 Every 50 work hours
- 4.3 Every 200 work hours
- 4.4 Storage
- 4.5 Lubrication

### 5. SERVICING TIPS

#### Parts Catalogue

#### NOTE:

BERI UDYOG PVT. LTD reserves the right to modify machine design and specifications provided herein without any preliminary notice. Information provided herein is of descriptive nature. Performance quality may depend on soil quality.

# 1. TECHNICAL DATA

## 1.1 INTRODUCTION

This handbook contains operating and maintenance instructions plus a list of the parts supplied as spare parts for the rotary tiller.

Rotary tiller can only operate by means of a **cardan shaft** engaged to the PTO of an agricultural tractor equipped with lift and universal three point hitch.

Besides working the soil in open areas, the particular and specific design of this implement makes it ideal for working between the rows of orchards and vineyards etc. Regular and satisfactory operations together with economic and long lasting use of the implement depend on the compliance with the instructions given in this handbook. It is therefore advisable to strictly comply with the following instructions in order to prevent faults that could jeopardize the correct and long lasting operation of the implement.

Compliance with the instructions in this handbook is also important though **manufacturer declines all and every responsibility for damage to persons or property caused by negligence and failure to comply with these instructions.**

The manufacturer shall, however, remain at the customer's disposal for immediate and thorough assistance together with anything else that may be required in order to ensure the correct operation and maximum efficiency of the implement.

## 1.2 WARNING SIGNAL

### REMEMBER SAFETY FIRST

Operator must read the instruction manual before operating the rotary tiller.

Do not allow anyone to operate this equipment who has not fully read and comprehended this manual and who has not been properly trained in the safe operation of the equipment.



## 1.3 DANGER SIGNAL

1. Sharp objects could be thrown up keep a safe distance from the rotary tiller.
2. Risk of injury to leg
3. Keep away from the moving parts. Never remove guards while working.
4. Your implement is not designed to carry passengers - NO RIDER
5. Never allow anyone to stand between the tractor and implement while an operator is backing up to the implement.
6. Keep away from the cardan shaft. Keep away from the moving parts.

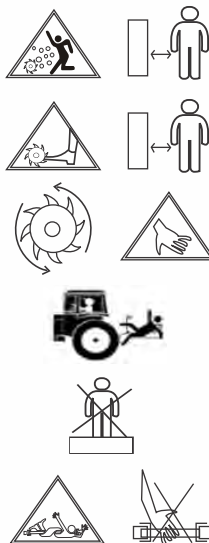

## 1.4 PERSONAL PROTECTIVE EQUIPMENT



1. Do not wear loose fitting dress, dangling jewellery. Long hair should be tied back to avoid entangling.
2. Wear appropriate footwear. Soft cloth shoes or sandals are not safe around any type of equipment.
3. Wear hearing protection such as earplugs or other devices that will minimize sounds. But will not interfere with your ability to hear traffic or other noises that may alert you to potential hazards.
4. Do not operate any machinery while talking on a cell phone or other portable devices such as MP3 players, as these are considered distractions- operating any farm equipment requires the operator's full attention.

## 1.5 EQUIPMENT SAFETY GUIDELINES



1. Read safety instructions for both the tractor and this tiller before use.
2. Never exceed the advised limits of the tractor or the tiller.
3. This equipment is dangerous to children and those unfamiliar with its operation. **DO NOT ALLOW** children to operate or play around equipment.
4. Operator should be an adult who is familiar with operating the tractor and the tiller.

Operator should be physically and mentally fit before operating machinery. Fatigue, stress, alcohol and drugs may impair the ability for safe farm machinery operation.

## 1.6 INDICATOR SIGNALS

1. Coupling point for lifting (Indicating the maximum capacity)
2. Oil fill plug.
3. Oil drain Plug.
4. Oil Level Plug.
5. Greasing point.
6. Identification Plate.

## 1.7 IDENTIFICATION

Each individual rotary tiller has an identification plate indicating the following details, which should be copied into the handbook along with the date of purchase:

1. Machine type.
2. Machine model.
3. Serial number.
4. Year of manufacture.

## 2. SAFETY AND ACCIDENT PREVENTION

Pay great attention to the danger signal indicated in this handbook. There are three types of danger signals:

**Danger:** This signal warns for serious injuries, death or long-term health risks would be caused by failure to correctly carry out the described operations.

**Warning:** This signal warns for serious injuries, death or long-term health risks that can be caused by failure to correctly carry out the described operations.

**Caution:** This signal warns for damage to the machine could be caused by failure to carry out the described operations.

Thoroughly read all the instructions before using the rotary tiller. Contact the technicians of your authorized dealer in case of doubt. The manufacturer declines all and every responsibility for injury/accidents in event of non-compliance of following safety and accident preventing provisions.

- 1) Comply with the instructions given by the danger symbols in this handbook and affixed to the steering hoe itself.
- 2) Never touch any moving part.
- 3) Minor maintenance and adjustments to the rotary tiller must always be carried out when the engine is off and the tractor braked.
- 4) It is absolutely forbidden to carry passengers or any animals on the rotary tiller.
- 5) It is absolutely forbidden for a person without a driving license, untrained person or those in precarious health conditions to drive the tractor with the rotary tiller mounted.
- 6) Strictly comply with all the recommended accident preventing measures described in this handbook.
- 7) Assembly of a rotary tiller on the tractor will shift the weights on the axles. It is therefore advisable to add weights to the front part of the tractor in order to balance the weights on the axles themselves.
- 8) The coupled implement may only be controlled through the cardan shaft complete with the necessary safety devices for overloads and with the appropriate chains. Keep away from the cardan shaft while it is turning.
- 9) Before starting the tractor and implement, always check that all safety devices guarding transport and use are in perfect conditions.
- 10) The instruction labels affixed to the machine give useful advice on how to prevent accidents.
- 11) Always comply with the Highway Code in force in your country, when travelling on public roads.
- 12) Comply with the maximum permissible weight on the axle of the tractor, the total adjustable weight, transport regulations and the highway code.
- 13) Always be familiar with the controls and their operation before starting to work.
- 14) Avoid sharp turns as this may cause implement to ride up on the tractor's wheels and might result in serious injury and damage to your equipment.
- 15) As indicated, couple the implement to a tractor of adequate power and configuration, using a device (lift) conforming to the precautions.
- 16) Take the utmost care during the implement coupling and release phases.
- 17) Any accessories for transport must be equipped with adequate signals and guards.
- 18) Never leave the driving seat while the tractor is moving.
- 19) It is very important to remember that the road holding, steering and braking capacity may be notably influenced by the presence of towed or mounted implement.
- 20) Always take care of the centrifugal force exercised by the position of the center of gravity, when turning corners with the implement mounted.
- 21) Before engaging the PTO, check that the rpm rate is the same as prescribed. Never exchange the 540-rpm rate for 1000-rpm or vice versa.
- 22) It is absolutely forbidden to stand within the operative range of the machine where there are moving parts.
- 23) Before leaving the tractor, lower the implement coupled to the lift unit, stop the engine, engage the hand brake and remove the ignition key from the control panel.

- 24) It is strictly prohibited to stand between the tractor and the implement when the engine is running and the cardan shaft is engaging without having first engaged the hand brake and placing a block or stone under the wheels to prevent them from moving.
- 25) Always set the lift control lever to the locked position before coupling or releasing the equipment from the three-point coupling.
- 26) The category of the implement coupling pins should correspond to that of lift coupling.
- 27) Take care when working near the lift links. This is a very dangerous zone.
- 28) It is absolutely forbidden to stand between the tractor and the implement when handling the lift control from outside.
- 29) Fix the side lift links with the relative chains and idlers during the transport phase.
- 30) Set the control lever of the hydraulic lift to the locked position during road transport with the implement raised.
- 31) Only use the cardan shaft recommended by the manufacturer.
- 32) Check the cardan shaft guard frequently and periodically. It must always be in a proper condition.
- 33) Take great care of the cardan shaft guard, both in the transport and working positions.
- 34) The cardan shaft must only be installed or dismantled whilst the engine is off.
- 35) Take great care to ensure that the cardan shaft is correctly assembled and safe, and carefully check the P.T.O. of the rotary tiller and of the tractor.
- 36) Lock the rotation of the protection devices and read the respective cardan shaft Instruction manual thoroughly.
- 37) Before engaging the PTO, ensure that there's nobody in the field of action of the machine and that the selected running rate corresponds to the permissible value.
- 38) Never engage the PTO when the engine is on.
- 39) Always disengage the PTO when the cardan shaft is set at an excessively open angle (never beyond 10 degrees) and when it is not in use.
- 40) Only clean and grease the cardan shaft when the PTO is disengaged, the engine is off, the handbrake engaged and the ignition key is removed.
- 41) Rest the cardan shaft on its stand when not in use.
- 42) Refit the protective cap on the PTO shaft after having dismantled the cardan shaft.
- 43) Over use of the machine can overheat the gear box unit and parts of the hydraulic circuit. Never touch these parts immediately after use as they are very hot and can cause burns.
- 44) Never carry out maintenance or cleaning work unless the PTO has been disengaged, the engine switched off, the hand brake engaged and the tractor locked in position by a block or stone under the wheels.
- 45) Periodically check for all nuts and bolts to be fully tightened. Re-tighten them if necessary.
- 46) Always place adequate supports under the implement when servicing the machine or replacing the hoe blades with the implement raised.
- 47) Before working on the rotary tiller rotor, disengage the PTO, switch off the tractor engine, engage the hand brake and check that the blades are still.
- 48) Only use the recommended oils & grease.
- 49) The spare parts must correspond to the requirements established by the manufacturer. Only use genuine spare parts.
- 50) The safety instructions must always be perfectly visible. They must be kept clean and should be replaced if they become illegible. Replacements are available on request from your local dealer.
- 51) The instruction manual must be kept for as long as the machines last.

### 3. INSTRUCTIONS FOR OPERATOR

#### MACHINES SUPPLIED PARTLY

##### 3.1 BROKEN-DOWN

When large volumes are involved, machines can be supplied with parts detached or removed (but always in the same packaging units).

Normally the 3-point frame is shipped separate and will later be fixed to the machine at the customer premises. Execute these installation operations with the utmost care.

Refer to the list of parts in the spare parts catalogue. In particular, apply the screw tightening torques as listed in the chart.

##### 3.2 BEFORE USE

Before starting the machine, check that:

1. The machine is perfectly in order that the lubricants are at the correct levels.
2. Check the rotary tiller is correctly fitted & positioned to obtain the right working depth.
3. Check air breather valve is fitted on gear box and side gear cover.

#### WARNING

None of the following servicing, adjustment and the preparation operations should be carried out unless the PTO is disengaged, the machine is on the ground, the tractor engine is off and the tractor itself is safely parked & braked.

##### 3.3 HITCHING TO THE TRACTOR

The rotary tiller is coupled to the tractor when the tiller is on the ground. The ground area should be flat.

All the rotary tillers can be attached to any tractor with a class 1 or 2 universal 3-point hitch.

Depending on the precise dimensions of these two of hitches, find the best position for the rotary tiller by moving the front plates along the square tube and insert the pin in the holes corresponding to the correct diameter for the tractor's parallel arms.

#### DANGER

Mounting of any implement to a tractor is a very dangerous operation and must only be carried out with the utmost care in compliance with the instructions.

The correct tractor/steerage hoe position is established by setting the implement at such a distance from the tractor that the universal coupling remains 5-10 cm from its maximum closing position. Now proceed in the following way:

1. Near the lift bars, setting them in the most suitable place insert the pin into the relative hole and lock in place with the lynch pins.
2. Lock the lift links using the relative chains and couplings parallel to the tractor.
3. Engage the cardan shaft and check that it is perfectly locked on the PTO. Check that the guard is free to turn and fix it with a relative latch. Remove the cardan shaft support and reposition it by fixing it on the relative hook.
4. Connect the upper third point and correctly regulate by means of the adjuster checking that the upper surface of the steerage hoe is parallel to the ground. This is very important since it achieves parallelism between the axis of the steerage hoe and that of the tractor PTO. When the implement operates in these conditions, there will be less stress on the PTO itself while the cardan shaft and implement will be much less subjected to wear.
5. Besides supporting the leveling plate and acting as shock absorber for it during road transport, the spring ram prevents the steerage hoe from overturning when parking. The effect of the leveling plate on the soil can be increased or decreased depending upon the position, established by the split pin in the various holes in the ram tube.

6. When the machine is operating parking stand should be removed. Parking stand should only be installed when the rotary tiller has been lowered to the ground & the machine is parked.

##### 3.4 CARDAN SHAFT

###### Cardan Shaft adaptation

The cardan shaft, supplied with the machine, is of standard length. Therefore, it might be required to adapt the cardan shaft. In that case, before taking any step consult the Manufacturer for the eventual adaptation.

#### CAUTION

When the cardan shaft is fully extended, the two tubes must overlap by at least 10-15 cm. When fully inserted, the minimum play must be 4cm.

If the implement is used on another tractor, always check that the guards completely cover the rotating parts of the cardan shaft.

#### CAUTION

1. Never allow the steerage hoe to operate out of the soil. During work, avoid turning corners while the implement is working. Never work in reverse. Always raise the implement in order to reverse or change direction.
2. During transport, or whenever the implement must be raised, it is advisable to adjust the lift unit of the tractor so that the implement itself is not raised more than about 35 cm from the ground.
3. Do not drive on public highways if the machine is dirtied with soil, grass as it hampers the road traffic.
4. Lower the machine slowly to allow the blades to gradually penetrate the soil.
5. Do not allow it to drop violently on to the ground. To do this would strongly stress all the machine components and could damage them.

##### 3.5 WORKING DEPTH

Rotary tiller working depth is regulated on the basis of the position of the following devices:

1. Side skids

**Machine with skids:** To adjust working depth on this type of machine you must loosen the adjustment pin and raise or lower the skid to the desired extent. Then reposition the pin. Both skids should be subjected to this operation, which will vary according to the type of soil.

##### 3.6 HOE BLADES

Check the degree of wear and condition of the hoe blades daily. If the blades accidentally bend (or break) during work, they must be immediately replaced.

Remember to mount the new hoe blade in exactly the same position as the old one. If several hoe blades must be replaced, it is advisable to remove and assemble one hoe blade at a time in order to prevent positioning errors.

The steerage hoes are normally equipped with 4 blades per flange. When the soil is dry to clog it is, however, possible to mount 6 hoe blades per flange. The heads of the bolts fixing the hoe blades in place must be on the side of the hoe blades themselves, while the nut with relative washer must be on the flange side. Apply the tightening torques as listed in the chart. If the hoe blades must be changed, remember to set the new blades in the same positions as the dismantled ones.

### 3.7 IN WORKING

Start working with the PTO at running rate, gradually lowering the steerage hoe into the soil. Never excessively press down on the accelerator pedal when the PTO is engaged. This could be very harmful for both the steerage hoe and the tractor itself. When choosing how much to break up the soil that is to be rotary hoed the following points must be considered:

1. The type of soil (mixed, sandy, clayed etc.)
2. How deep to hoe
3. The forward moving speed of the rotary tiller/tractor.

The soil is best broken up and rotary hoed with a slow forward moving speed of the tractor, with the leveling blade lowered and a blade carrying rotor rotation speed of about 180-210 rpm. The plank helps to produce a well-leveled and smooth surface after hoeing.

If the plank is raised the sods/clog are no longer broken up and there will not be a smooth, level finish.

### 3.8 HOW IT WORKS

Position the Plank according to how finely broken soil should be. Position the depth of the two skids that are on the sides of the rotary tiller. Start to move the tractor forward gradually lowering the rotary tiller.

After a short distance check whether the soil is being hoed to the depth required, broken up finely enough and levelled enough.

### CAUTIONS

In order to prevent breakages or damage, the speed of the tractor must never exceed 2-5 km/hr while the implement is working.

### 3.9 TROUBLESHOOTING HINTS FOR THE TRACTOR OPERATOR

#### INSUFFICIENT DEPTH

1. Check the positioning of the two depth skids.
2. Move forward slower as the power of the tractor may be insufficient.
3. If the soil is too hard a second or third hoeing may be required.
4. If the hoe blades are rotating on top of the soil instead of cutting into it proceed more slowly.

#### THE SOIL IS TOO FINELY BROKEN UP

1. Raise the leveling blade.
2. Increase the forward moving speed of the tractor.

#### THE SOIL IS NOT BROKEN UP FINELY ENOUGH

1. Lower the leveling blade.
2. Reduce the tractor speed.
3. Don't work soil that is too wet.
4. In the rotary hoes fitted with a leveling bar, raise or lower this so as to keep the sods closer to the hoe blades.

#### CLOGGING UP THE ROTOR

1. The soil is too wet for hoeing.
2. Raise the leveling blade.
3. Reduce the tractor speed.
4. Reduce the number of the hoe blades per flange from six to four.
5. Avoid hoeing where there is long grass .

#### THE ROTARY HOE BOUNCES OVER THE SOIL OR VIBRATES

1. There are foreign bodies caught between the hoe blades.
2. The hoe blades have been incorrectly assembled thereby not forming. The helix shape or with the blunt edge placed to cut into the soil first instead of the cutting edge.
3. Worn or broken hoe blades.
4. The rotor is deformed because of blows to the central part caused by foreign bodies present during hoeing.

#### OTHER PROBLEMS

The rotary hoe does not hoe to the same depth over the whole width. E.g. if it hoes too deeply on the right side shorten the right arm of the lift bars and regulate the position of the right hand skid.

#### WORKING ON A HILL/SLOPE

Where possible always try to 'work up' the slope. If this is not possible avoid hoeing along the contours of the hill and hoe up and down the slope to avoid a terracing effect.

#### PRACTICAL NOTES

The hoed soil should be on the right of the driver the best system is to hoe the alternate strips.

#### 3.10 PARKING

#### WARNING

Comply with the following instruction in order to ensure that the implement remains stable when released from the tractor.

1. Besides supporting the leveling plate and acting as a shock absorber for it during road transport, the spring ram prevents the steerage hoe from over turning when parking.
2. Hold the cardan shaft with a suitable support.

#### 4. MAINTENANCE

The various servicing operation are listed in the following paragraphs.

Lower running costs and longer machine life depend on constant and methodical compliance with these operations.

## CAUTION

The given frequencies are indicative and refer to normal conditions of use. They may therefore be subjected to variations in relation to the type of service, in more or less dusty environment, seasonal factors, etc.

In the case of heavy-duty condition, the maintenance operation should obviously be more frequent.

Before injecting grease into the lubricators, the greasing points must be thoroughly cleaned to prevent mud, dust or foreign bodies from mixing with the lubricants, thus reducing or even annulling its lubricating effect.

When topping up or changing the lubricant, always ensure that the oil is of the same type as that used previously.

## WARNING

Always keep oil and greases well away from children's reach. Always thoroughly read the warnings and precautions indicated on the containers.

Avoid contact with the skin.

Always thoroughly and fully wash after use. The utilized oils should be treated in compliance with the current anti-pollution laws.

### 4.1 EVERY 8 WORK HOURS

Grease the cardan shaft cross journals.

Check that the bolts fixing the hoe blades are well tightened.

### 4.2 EVERY 50 WORK HOURS

Check the level of the oil in the gearbox or in the reduction unit and top up to the level mark on the rod as necessary.

**Transmission lateral part chain:** check the level of the oil in the side casing of the transmission unit.

Add oil through the fill plug if necessary. It should flow from the level plug.

### 4.3 EVERY 200 WORK HOURS

Change the oil in the gearbox or in the reduction unit and transmission casing by completely draining of the old oil through the drain plug, under the reduction unit and through the transmission drain plug.

### 4.4 STORAGE

It is advisable to proceed in the following way at the end of the season or if the machine is to remain inactive for a long period of time:

1. Wash the implement, particularly removing any fertilizer and/or chemical products, and then thoroughly dry it.
2. Carefully check for any damaged or worn parts and replace these if necessary.

3. Fully check screws or bolts, particularly those fixing the hoe blades.
4. Thoroughly lubricate the implement and lastly protect it with a plastic sheet. Store it in a dry place.

Careful compliance with these instructions will be all to the advantage of the user who will be sure to use an implement in perfect conditions when work begins again. Remember that the manufacturer is always at your disposal for any assistance or spare parts as may be required.

## 4.5 LUBRICANTS

It is advisable to use SAE 140 EP Grade OIL or equivalent for the gear box unit and side transmission.

It is advisable to use high quality grease for all greasing points.

## 5. SERVICING TIPS

1. **Problem**-- P.T.O shaft is rotating with constant speed but not the gear box.

**Cause of problem** -- Safety bolt might be broken

**Solution** -- Replace the safety bolt.

- a) Remove the P.T.O shaft from the R.T side.
- b) Dislodge the safety bolt and replace it.

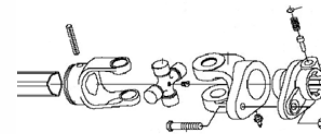

2. **Problem**—P.T.O shaft is making noise/ vibration.

**Cause of problem** – P.T.O cross is broken.

**Solution** –Change the P.T.O cross.

- a) Take the P.T.O shaft and check the cross of both side by rotating it.
- b) Remove the lock of the cross which is broken.
- c) Take out the cross by using hammer gently.
- d) Insert the new one properly then lock it.
- e) Rotate the yoke, it should rotate properly.
- f) Make the greasing properly.

3. **Problem**—Yoke is not fitting on the pinion shaft.

**Cause of problem** – Yoke pin is broken.

**Solution** –Replace the yoke pin.

- a) Clear the head of the pin push it with with hammer and remove it
- B) Replace it with new one.
- c) Take care of proper cleaning and greasing.

4. **Problem**—Rotary tiller is not taking proper depth.

**Cause of problem**— Side depth skids need to be adjusted.



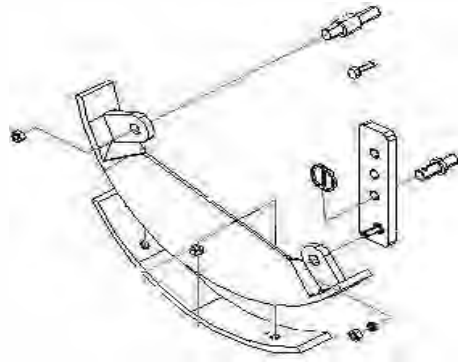

**Solution –**

- a) Lose the side skid bolt .
- b) Shift the hole to the upper side.

**2. Problem—**R. T. is taking on one side more depth.

**Cause of problem –**linkage is not proper

**Solution –**Linkage adjustment should be proper.

- a. Tractor linkage should be tight.
- b. There should not be any play more then 1.5”(38MM).
- c. At the time of attaching the rotary tiller the R. T should be in proper leveled position.
- d. Both side skids should be in same bolt position.

**3. Problem—**Gear box is noisy.

**Cause of problem –**Play in bearing or teeth broken.

**Solution –**Replace the bearing or bevel gear.

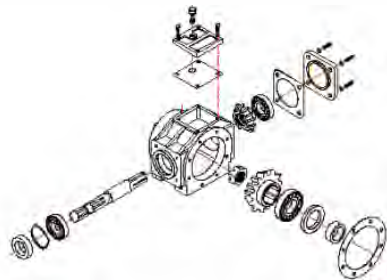

- a) Open the top cover to see the wear of the teeth
- b) If the teeth of the gear is broken the bevel set needs to be replaced.
- c) Pull out the gear box and open the big flange.
- d) Then remove the back plate
- e) Pull out the pinion shaft using hammer or press machine.
- f) Replace the bearing, gear and seals.
- g) Make the fitment in the same way using new gasket.
- h) The gear should rotate freely.
- i) Assemble it back the breather valve should be clean and oiling should be checked.

**2. Problem—**Gear shafts are rotating but not the chain/rotor

**Cause of problem –**Transmission shaft/ chain/ RD shaft is broken

**Solution –**Open the chain cover and replace the part which is broken.

- a. First remove the lock & loose the check nut.
- b. Pull out the sprocket assembly with chain.
- c. If the transmission shaft is broken, follow the same process as above and replace the shaft then assemble the gear box with rotary tiller.
- d. If chain is broken then replace the chain and assemble the sprockets together with chain & then tighten the check nuts.

For RD shaft the process will be different

- e. First open the flange bolt of the rotor on both side (RD shaft and Dead shaft) and remove the rotor.
- f. Loosen the check nut of RD shaft and hammer it till it gets out from the RD shaft hub & then replace the RD shaft and tight the check nut. Take care of the seal as it should not be harmed with this replacement.

The same process be followed for dead shaft replacement.

**3. Problem—**Oil leakage from the RD shaft hub or dead hub.

**Cause of problem –**Seal is wearing out needs to replaced it.

**Solution –**Open the hub assembly as before

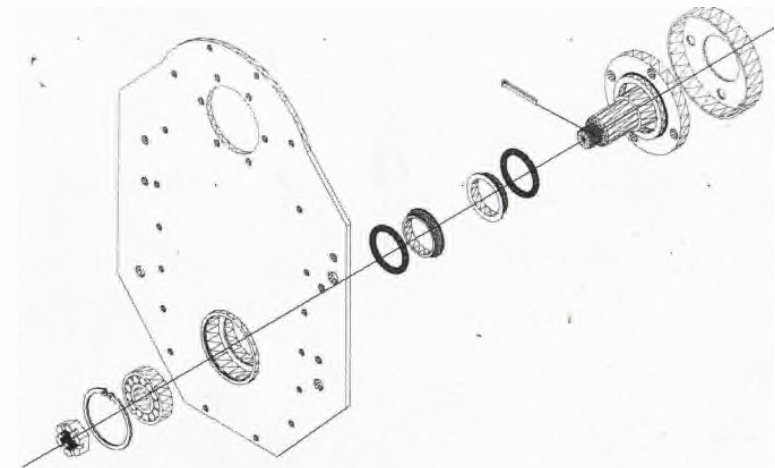

- a. Take out the hub from the plate by loosening the bolts
- b. Remove the lock and pull out the shaft.
- c. Pull out the seal from both shaft and hub then replace it with new one
- d. Inspect the position of bearing and hub if it is ok. Clean it and assemble as before.
- e. Proper greasing is very necessary in assembly processes.

| ROTARY TILLER COMPLETE ASSEMBLY |                                   |           |     |
|---------------------------------|-----------------------------------|-----------|-----|
| SR. NO                          | DESCRIPTION                       | ITEM CODE | QTY |
| 1                               | RT FRAME ASSEMBLY 1.25 MTR        | 70010177  | 1   |
|                                 | RT FRAME ASSEMBLY 1.45 MTR        | 70010041  |     |
|                                 | RT FRAME ASSEMBLY 1.65 MTR        | 70010044  |     |
|                                 | RT FRAME ASSEMBLY 1.85 MTR        | 70010045  |     |
|                                 | RT FRAME ASSEMBLY 2.05 MTR        | 70010046  |     |
| 2                               | HEX HEAD BOLT 8X40X1.25MM         | 10260002  | 2   |
| 3                               | HEX HEAD BOLT 8X25X1.25MM         | 10260360  | 16  |
| 4A                              | BREATHER NUT 22X1.5MM             | 10280010  | 1   |
| 4B                              | OIL LEVEL INDICATOR               | 10300117  | 1   |
| 5                               | GEAR COVER                        | 10150030  | 1   |
| 6                               | BREATHER VALVE                    | 10190001  | 1   |
| 7                               | BEARING 3209                      | 10050013  | 2   |
| 8                               | SPACER 45X4                       | 10300096  | 1   |
| 9                               | SPUR GEAR 19T-8S                  | 10250072  | 1   |
| 10                              | INTERNAL CIRCLIP B85              | 10390032  | 1   |
| 11                              | HEX. HEAD BOLT M10X35X1.5         | 10260353  | 14  |
| 12                              | SPRING WASHER 8MM                 | 10270001  | 18  |
| 13                              | NYLOCK NUT M8X1.25                | 10280027  | 18  |
| 14                              | CASTLE NUT M30X1.5                | 10280093  | 2   |
| 15                              | CASTLE NUT M36X2                  | 10280071  | 1   |
| 16                              | SPLIT PIN 1/8X2"                  | 10020074  | 2   |
| 17                              | SPUR GEAR 25T-10S                 | 10250074  | 1   |
| 18                              | SPUR GEAR 33T-10                  | 10250073  | 1   |
| 19                              | DEPTH SKID PIN 69                 | 10020002  | 2   |
| 20                              | DEPTH SKID PIN 90                 | 10020001  | 2   |
| 21                              | IDLER PIN                         | 10020004  | 1   |
| 22                              | HEX. HEAD BOLT M12X35X1.75        | 10260028  | 10  |
| 23                              | SPRING WASHER 12MM                | 10270003  | 28  |
| 24                              | NYLOCK NUT M12X1.75               | 10280025  | 28  |
| 25                              | HEX. HEAD BOLT M12X50X1.75        | 10260363  | 14  |
| 26                              | HEX. HEAD BOLT M12X40X1.75        | 10260355  | 4   |
| 27                              | PLAIN WASHER 14MM                 | 10270030  | 4   |
| 28                              | TRANSMISSION PIPE LOWER CLAMP     | 10220049  | 2   |
| 29                              | TRANSMISSION PIPE UPPER CLAMP     | 10220050  | 2   |
| 30                              | HEX HEAD BOLT M12X60X1.75         | 10260010  | 4   |
| 31                              | DEPTH SKID ASSEMBLY LHS           | 73420005  | 1   |
| 32                              | DEPTH SKID ASSEMBLY RHS           | 71570023  | 1   |
| 33                              | SPRING WASHER 18MM                | 10270006  | 2   |
| 34                              | NYLOCK NUT M18X1.5MM              | 10280006  | 6   |
| 35                              | <b>3-POINT LINKAGE ASSEMBLY</b>   | 73570005  | 1   |
| 36                              | RT FRONT LEVER PLATE (RHS)        | 73570006  | 1   |
| 37                              | RT FRONT LEVER PLATE (LHS)        | 73570007  | 1   |
| 38                              | RT TPL SIDE SUPPORT PLATE         | 73570008  | 2   |
| 39                              | RT TPL MIDDLE SUPPORT PLATE       | 73570009  | 1   |
| 40                              | HEX HEAD BOLT 16X105X2MM          | 10260134  | 2   |
| 41                              | BUSH 17X32X52MM (L)               | 10070004  | 2   |
| 42                              | SPRING WASHER 16MM                | 10270005  | 2   |
| 43                              | NYLOCK NUT M16X2                  | 10280005  | 2   |
| 44                              | SPRING WASHER 10MM                | 10270002  | 4   |
| 45                              | NYLOCK NUT M10X1.5                | 10280002  | 4   |
| 46                              | FRONT LINK BRACKET UPPER CLAMP    | 10120010  | 2   |
| 47                              | FRONT LINK BRACKET LOWER CLAMP    | 10120011  | 2   |
| 48                              | TILLER PIN 28X145MM WITH HANDLE   | 10020047  | 2   |
| 49                              | LINCH PIN 10MM                    | 10020022  | 4   |
| 50                              | DEPTH SKID ADJUSTER STUD ASSEMBLY | 71570022  | 2   |

ROTARY TILLER COMPLETE ASSEMBLY

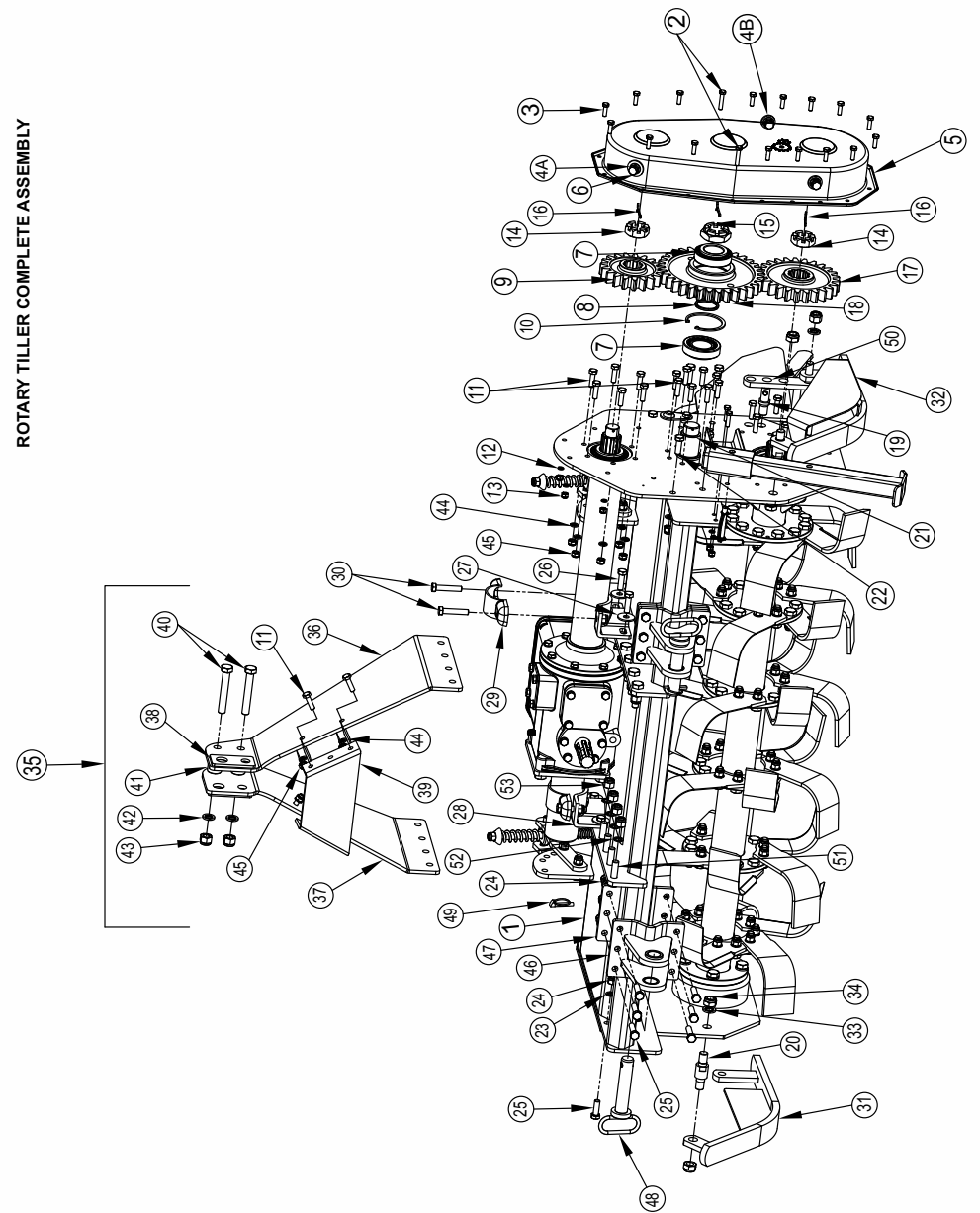

| ROTARY TILLER COMPLETE ASSEMBLY   |   |           |     |
|---|---|-----------|-----|
| SR. NO  | DESCRIPTION   | ITEM CODE | QTY |
| 51  | HEX HEAD BOLT 14X50X2 MM  | 10260386  | 8   |
| 52  | SPRING WASHER 14MM  | 10270004  | 12  |
| 53  | NYLOCK NUT M14X2  | 10280090  | 8   |
| 54  | HEX HEAD BOLT 14X35X2 MM  | 10260372  | 4   |
| 55  | FRAME-SHOCKER HOLDING CLAMP   | 70020048  | 4   |
| 56  | RT GEAR BOX SIDE MOUNTING ASSEMBLY (FIELDKING MULTISPEED)               | 74790002  | 1   |
|   | GEARBOX SIDE SUPPORT MOUNTING ASSEMBLY 1.45 MTR (TERMINATOR MULTISPEED) | 78750055  |     |
|   | GEARBOX SIDE SUPPORT MOUNTING ASSEMBLY 1.65 MTR (TERMINATOR MULTISPEED) | 78750031  |     |
|   | GEARBOX SIDE SUPPORT MOUNTING ASSEMBLY 1.85 MTR (TERMINATOR MULTISPEED) | 78750033  |     |
| GEARBOX SIDE SUPPORT MOUNTING ASSEMBLY 2.05 MTR (TERMINATOR MULTISPEED) | 78750034  |           |     |
| 57  | PLANK ROD 1.25 MTR  | 10160035  | 2   |
|   | PLANK ROD 1.45 MTR  | 10160053  |     |
|   | PLANK ROD 1.65 MTR  | 10160054  |     |
|   | PLANK ROD 1.85 MTR  | 10160055  |     |
| 58  | PLANK ROD 2.05 MTR  | 10160056  | 2   |
| 59  | PLANK ROD PLATE   | 10160031  | 2   |
| 59  | SHOCKER-PLANK ATTACHMENT INNER SUPPORT FLAT                             | 70020026  | 2   |
| 60  | CSK BOLT 10X35X1.5MM  | 10260113  | 4   |
| 61  | HEX HEAD BOLT 12X70X1.75MM  | 10260407  | 2   |
| 62  | SHOCKER-PLANK ATTACHMENT (U-CLAMP) 5 MM THK.                            | 10220051  | 2   |
| 63  | RT SHOCKER ASSEMBLY (MINI)  | 79820001  | 2   |
| 64  | SHOCKER ROD WITH LOWER CUP (MINI)                                       | 10160061  | 2   |
| 65  | SHOCKER BIG SPRING (MINI)   | 10210027  | 2   |
| 66  | SHOCKER ROD BUSH NEW (MINI)   | 10070102  | 2   |
| 67  | SHOCKER SMALL SPRING (MINI)   | 10210026  | 2   |
| 68  | SHOCKER SPRING CUP UPPER NEW (MINI)                                     | 10180040  | 2   |
| 69  | NYLOCK NUT M12X1.75 (P)   | 10280025  | 2   |

ROTARY TILLER COMPLETE ASSEMBLY

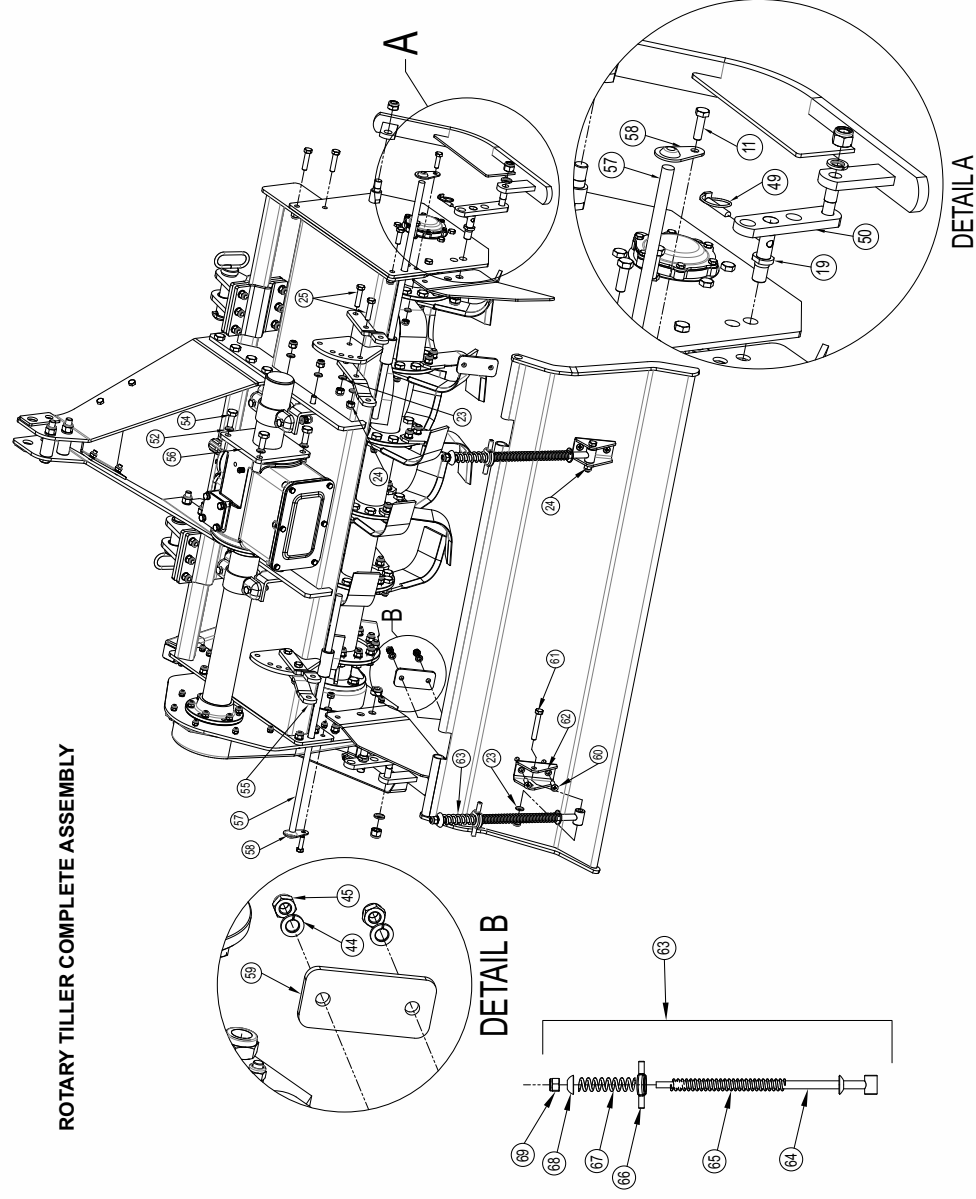

| ROTARY TILLER SIDE PLATE AND ROTOR ASSEMBLY |  |           |               |
|---|--|-----------|---------------|
| SR. NO                                      | DESCRIPTION                                | ITEM CODE | QTY           |
| 70  | HEX HEAD BOLT 6X16X1MM (P)                 | 10260359  | 6             |
| 71  | DEAD HUB CAP ROUND                         | 10180036  | 1             |
| 72  | GASKET DEAD HUB CAP                        | 10040026  | 1             |
| 73  | SIDE PLATE LHS                             | 70050005  | 1             |
|   | RT SIDE PLATE BIG LHS                      | 70040009  |               |
| 74  | SPLIT PIN 1/8X2.5 INCH                     | 10020097  | 1             |
| 75  | CIRCLIP 95MM                               | 10390014  | 1             |
| 76  | BEARING 6308                               | 10050051  | 1             |
| 77  | DEAD HUB (OIL SEAL TYPE) (ROUND) NEW       | 10090021  | 1             |
| 78  | PLAIN NUT 10X1.5MM                         | 10280036  | 6             |
| 79  | OIL SEAL 55X75X15                          | 10010023  | 1             |
| 80  | DEAD SHAFT BUSH                            | 10070042  | 1             |
| 81  | DEAD AXLE SHAFT NEW ROUND (OIL SEAL TYPE)  | 10110002  | 1             |
| 82  | ROTOR COVER                                | 10150003  | 2             |
| 42  | SPRING WASHER 16MM                         | 10270005  | 8             |
| 83  | HEX HEAD BOLT M16X35X1.5MM                 | 10260369  | 8             |
| 84  | ROTOR ASSEMBLY (OIL SEAL TYPE) (1.25 MTS.) | 73190004  | 1             |
|   | ROTOR ASSEMBLY (OIL SEAL TYPE) (1.45 MTS.) | 73340003  |               |
|   | ROTOR ASSEMBLY (OIL SEAL TYPE) (1.65 MTS.) | 73350003  |               |
|   | ROTOR ASSEMBLY (OIL SEAL TYPE) (1.85 MTS.) | 73360003  |               |
|   | ROTOR ASSEMBLY (OIL SEAL TYPE) (2.05 MTS.) | 73370003  |               |
| 85  | HOE LHS (L TYPE)                           | 10060014  | 3 PER FLANGE  |
|   | HOE LHS (C TYPE)                           | 10060038  |               |
| 86  | HOE RHS (L TYPE)                           | 10060015  | 3 PER FLANGE  |
|   | HOE RHS (C TYPE)                           | 10060039  |               |
| 87  | HEX HEAD BOLT 14X40X1.5MM                  | 10260357  | 12 PER FLANGE |
| 88  | RD SHAFT BUSH                              | 10070002  | 1             |
| 89  | RD SHAFT (OIL SEAL TYPE) 10 SPLINES        | 10290017  | 1             |
| 90  | OIL SEAL 65X85X16(DOUBLE SPRING TYPE)      | 10010136  | 1             |
| 91  | RD HUB (OIL SEAL TYPE) (ROUND)             | 10090010  | 1             |
| 92  | BEARING 6310                               | 10050053  | 1             |
| 93  | CIRCLIP 118MM                              | 10390013  | 1             |
| 94  | GASKET RD HUB                              | 10040025  | 1             |
| 95  | RT SIDE PLATE RHS                          | 70040002  | 1             |
| 96  | NYLOCK NUT M14X1.5                         | 10280004  | 1             |

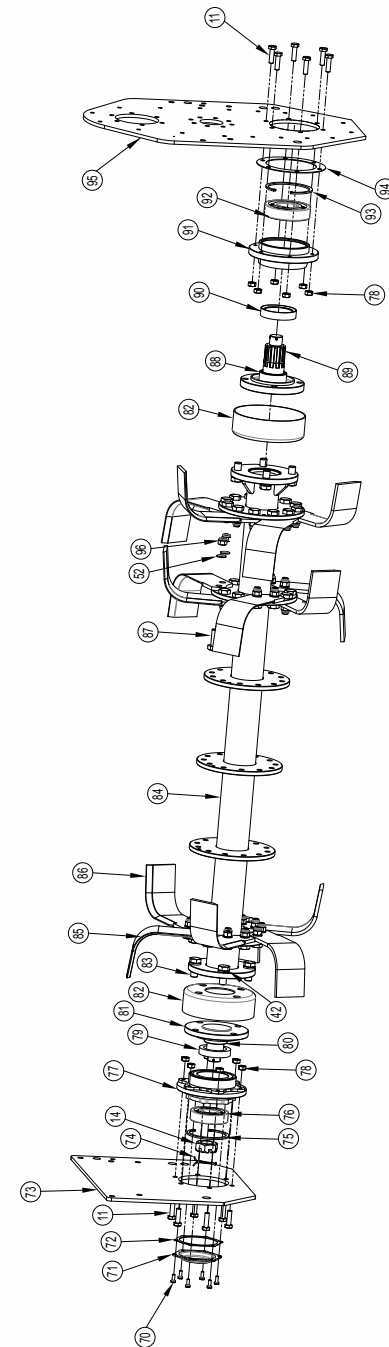

ROTARY TILLER SIDE PLATE AND ROTOR ASSEMBLY

| MULTI SPEED GEAR BOX ASSEMBLY |  |           |          |     |
|-------------------------------|--|-----------|----------|-----|
| SR. NO                        | DESCRIPTION  | ITEM CODE |          | QTY |
|                               |  | 540 RPM   | 1000 RPM |     |
| 1                             | GEAR BOX HOUSING (MULTISPEED) (13X25)                      | 10080002  |          | 1   |
| 2                             | DRIVE SHAFT (FIELDKING MULTISPEED)                         | 10290001  |          | 1   |
| 3                             | BEARING 30207  | 10050100  |          | 1   |
| 4                             | OIL SEAL 35X62X10  | 10010006  |          | 1   |
| 5                             | GASKET FRONT PLATE FIELDKING MULTISPEED                    | 10040074  |          | 1   |
| 6                             | MULTI SPEED GEAR BOX FRONT BEARING PLATE ROUND (13X25)     | 71940007  |          | 1   |
| 7                             | SPRING WASHER 10MM   | 10270002  |          | 20  |
| 8                             | HEX HEAD BOLT M10X30X1.5MM                                 | 10260396  |          | 16  |
| 9                             | MULTI SPEED GEAR BOX FRONT BEARING PLATE SQUARE (13X25)    | 71940008  |          | 1   |
| 10                            | BEARING 30210  | 10050097  |          | 1   |
| 11                            | PINION GEAR 13T  | 10250016  |          | 1   |
| 12                            | PINION SHAFT (FIELDKING MULTISPEED)                        | 10290025  |          | 1   |
| 13                            | BREATHER NUT 22X1.5MM                                      | 10280010  |          | 1   |
| 14                            | BREATHER VALVE   | 10190001  |          | 1   |
| 15                            | SPRING WASHER 16MM   | 10300122  |          | 1   |
| 16                            | HEX HEAD BOLT M10X25X1.5MM                                 | 10260361  |          | 4   |
| 17                            | TRANSMISSION PIPE ASSEMBLY-1.25 MTR (FIELDKING MULTISPEED) | 73920002  |          | 1   |
|                               | TRANSMISSION PIPE ASSEMBLY-1.45 MTR(FIELDKING MULTISPEED)  | 73830002  |          |     |
|                               | TRANSMISSION PIPE ASSEMBLY-1.65 MTR (FIELDKING MULTISPEED) | 73840002  |          |     |
|                               | TRANSMISSION PIPE ASSEMBLY-1.85 MTR (FIELDKING MULTISPEED) | 73850002  |          |     |
|                               | TRANSMISSION PIPE ASSEMBLY-2.05 MTR (FIELDKING MULTISPEED) | 73850002  |          |     |
| 18                            | GASKET BIG FLANGE (MULTI SPEED 540 RPM)                    | 10040046  |          | 1   |
| 19                            | TRANSMISSION SHAFT 1408S-1.25 MTR (13X25 MULTISPEED)       | 10290150  |          | 1   |
|                               | TRANSMISSION SHAFT 1408S-1.45 MTR (13X25 MULTISPEED)       | 10290094  |          |     |
|                               | TRANSMISSION SHAFT 1408S-1.65 MTR (13X25 MULTISPEED)       | 10290095  |          |     |
|                               | TRANSMISSION SHAFT 1408S-1.85 MTR (13X25 MULTISPEED)       | 10290096  |          |     |
|                               | TRANSMISSION SHAFT 1408S-2.05 MTR (13X25 MULTISPEED)       | 10290096  |          |     |
| 20                            | TRANSMISSION SHAFT BUSH (MULTISPEED13X25)                  | 10070066  |          | 1   |
| 21                            | OIL SEAL 55X80X10  | 10010002  |          | 1   |
| 22                            | BEARING 32211  | 10050009  |          | 1   |
| 23                            | BEVEL GEAR 25T   | 10250025  |          | 1   |
| 24                            | CASTLE NUT M30X1.5M  | 10280093  |          | 1   |
| 25                            | SPLIT PIN 1/8X2.5 INCH                                     | 10020097  |          | 1   |
| 26                            | GASKET SMALL FLANGE (6 HOLE)                               | 10040005  |          | 1   |
| 27                            | BEARING 32209  | 10050013  |          | 1   |
| 28                            | EXTERNAL CIRCLIP 35MM                                      | 10390029  |          | 2   |
| 29                            | SPACER BUSH (MULTISPEED 13X25)                             | 10070064  |          | 1   |
| 30                            | SPUR GEAR 17TX6 SPLINES (13X25)                            | 10250010  |          | 1   |
|                               | SPUR GEAR 14TX6 SPLINES (13X25)                            |           | 10250041 |     |
| 31                            | SPUR GEAR 19TX6 SPLINES (13X25)                            | 10250033  |          | 1   |
|                               | SPUR GEAR 22TX6 SPLINES (13X25)                            |           | 10250042 |     |
| 32                            | GASKET REAR PLATE FIELDKING MULTISPEED                     | 10040075  |          | 1   |
| 33                            | GEAR BOX BACK PLATE (13X25) MULTISPEED (SHEETMETAL)        | 71940015  |          | 1   |
| 34                            | SPRING WASHER 8MM  | 10270001  |          | 6   |
| 35                            | HEX HEAD BOLT 8X20X1.25MM                                  | 10260387  |          | 6   |
| 36                            | GASKET MULTI SPEED GEAR BOX TOP PLATE(13X25)               | 10040042  |          | 1   |
| 37                            | GEAR BOX TOP PLATE MULTI SPEED (13X25)                     | 71940016  |          | 1   |

MULTI SPEED GEAR BOX ASSEMBLY

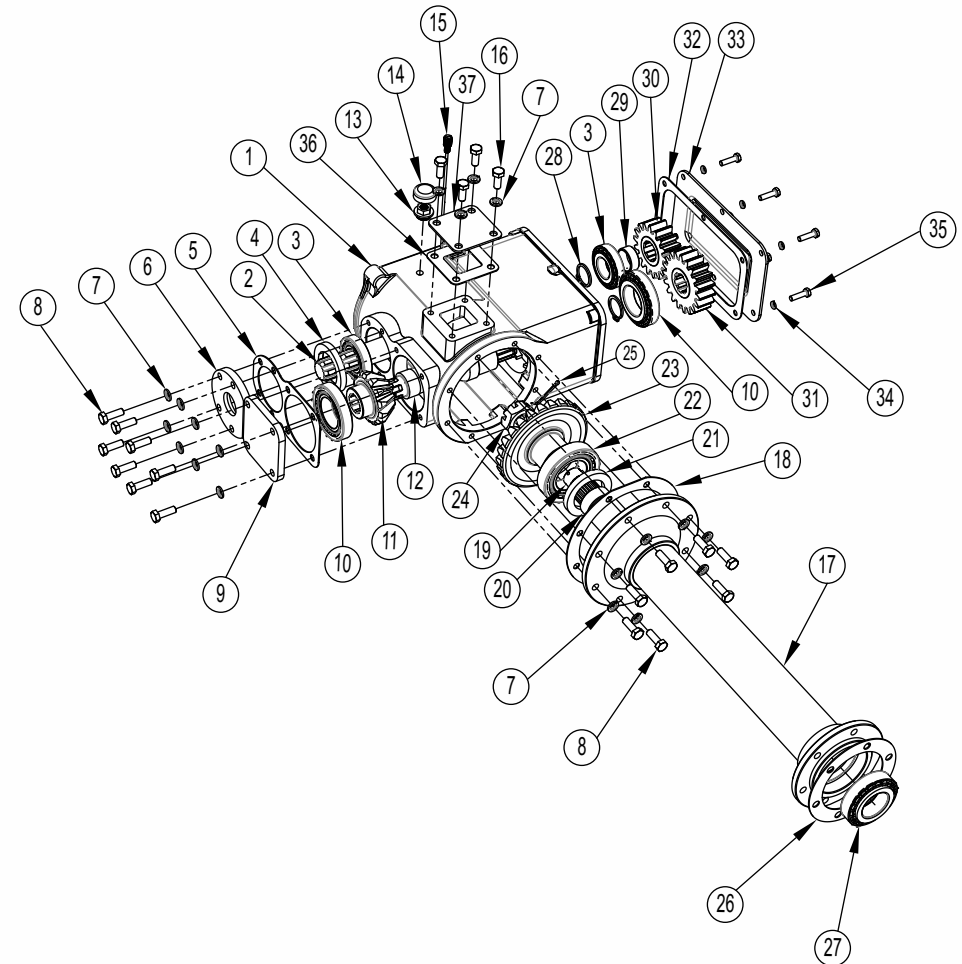

| SINGLE SPEED (11X20) GEARBOX ASSEMBLY |   |           |     |
|---------------------------------------|---|-----------|-----|
| SR.NO                                 | DESCRIPTION                                     | ITEM CODE | QTY |
| 1                                     | GEAR BOX HOUSING (SINGLE SPEED)11X20            | 10080001  | 1   |
| 2                                     | PINION SHAFT (SINGLE SPEED)                     | 10290010  | 1   |
| 3                                     | BEARING 30207                                   | 10050100  | 1   |
| 4                                     | CIRCLIP 72MM (INTERNAL)                         | 10390022  | 1   |
| 5                                     | OIL SEAL 35X72X10                               | 10010001  | 1   |
| 6                                     | PINION GEAR 11TX6 SPLINES                       | 10250018  | 1   |
| 7                                     | BEARING 30210                                   | 10050097  | 1   |
| 8                                     | CIRCLIP 95MM                                    | 10390014  | 1   |
| 9                                     | GEAR BOX REAR BEARING PLATE (SINGLE SPEED)      | 73620002  | 1   |
| 10                                    | SPRING WASHER 10MM                              | 10270002  | 14  |
| 11                                    | HEX HEAD BOLT M10X30X1.5MM                      | 10260396  | 12  |
| 12                                    | GASKET TOP PLATE GEAR BOX 109X109X1.5MM (11X20) | 10040033  | 1   |
| 13                                    | GEAR BOX TOP PLATE                              | 73620003  | 1   |
| 14                                    | DIP STICK                                       | 10300001  | 1   |
| 15                                    | BREATHER NUT 22X1.5MM                           | 10280010  | 1   |
| 16                                    | BREATHER VALVE                                  | 10190001  | 1   |
| 17                                    | HEX HEAD BOLT M10X25X1.5MM                      | 10260361  | 2   |
| 18                                    | BEARING 32209                                   | 10050013  | 1   |
| 19                                    | TRANSMISSION PIPE ASSEMBLY (1.25 MTS.)          | 71590004  | 1   |
|                                       | TRANSMISSION PIPE ASSEMBLY-1.45 MTR             | 73830001  |     |
|                                       | TRANSMISSION PIPE ASSEMBLY-1.65 MTR             |           |     |
|                                       | TRANSMISSION PIPE ASSEMBLY-1.85 MTR             | 73840001  |     |
|                                       | TRANSMISSION PIPE ASSEMBLY-2.05 MTR             | 73850001  |     |
| 20                                    | GASKET BIG FLANGE (8 HOLE) SS                   | 10040009  | 1   |
| 21                                    | TRANSMISSION SHAFT-1408S-S125                   | 10290006  | 1   |
|                                       | TRANSMISSION SHAFT 1408S-S145                   | 10290112  |     |
|                                       | TRANSMISSION SHAFT 1408S-S165                   | 10290113  |     |
|                                       | TRANSMISSION SHAFT 1408S-S185                   | 10290113  |     |
|                                       | TRANSMISSION SHAFT 1408S-S205                   | 10290114  |     |
| 22                                    | TRANSMISSION SHAFT BUSH                         | 10070038  | 1   |
| 23                                    | OIL SEAL 55X80X10                               | 10010002  | 1   |
| 24                                    | BEARING 32211                                   | 10050009  | 1   |
| 25                                    | BEVEL GEAR 20TX14 SPLINES                       | 10250007  | 1   |
| 26                                    | CASTLE NUT M30X1.5M                             | 10280093  | 1   |
| 27                                    | SPLIT PIN 1/8X2.5 INCH                          | 10020097  | 1   |

SINGLE SPEED (11X20) GEARBOX ASSEMBLY

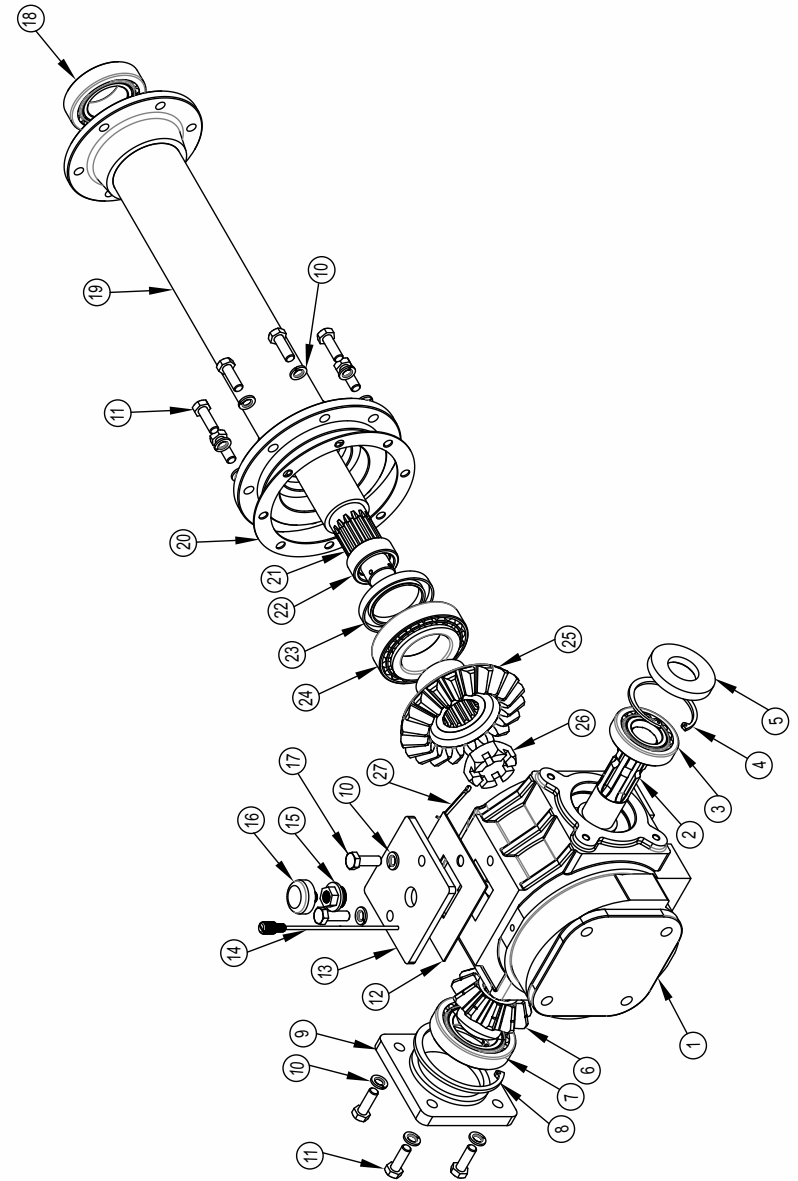

| SIDE DISC ASSEMBLY |  |           |     |
|--------------------|--|-----------|-----|
| SR. NO.            | DESCRIPTION  | PART CODE | QTY |
| 1                  | HEX HEAD BOLT M8X20X1.25                             | 10260387  | 6   |
| 2                  | SIDE DISC HUB FRONT COVER                            | 10150007  | 1   |
| 3                  | CASTLE NUT M30X1.5                                   | 10280093  | 1   |
| 4                  | BEARING 32307  | 10050008  | 2   |
| 5                  | SIDE DISC HUB  | 10090001  | 1   |
| 6                  | OIL SEAL 40X80X10                                    | 10010005  | 1   |
| 7                  | SIDE DISC HUB BACK COVER                             | 10150008  | 1   |
| 8                  | NYLOCK NUT M10X1.5MM                                 | 10280002  | 4   |
| 9                  | SPRING WASHER 10MM                                   | 10270002  | 4   |
| 10                 | SIDE DISC HUB AXLE (COMPLETE SET)                    | 10110001  | 1   |
| 11                 | PLAIN DISC 14 INCHX3MM (4 HOLE) (SIDE DISC RT)       | 10240001  | 1   |
| 12                 | CSK BOLT 10X35X1.5MM (8.8 GRADE)                     | 10260113  | 4   |
| 13                 | SIDE DISC MOUNTING PIPE ASSEMBLY                     | 73460001  | 1   |
| 14                 | HEX HEAD BOLT M12X20X1.75MM (8.8 GRADE)              | 10260408  | 4   |
| 15                 | PIN 19X90MM  | 10020026  | 1   |
| 16                 | LINCH PIN 10MM                                       | 10020022  | 1   |
| 17                 | RT SIDE DISC ATTACHMENT FRAME ASSEMBLY               | 73450008  | 1   |
| 18                 | FRONT BRACKET-SHEETMETAL (DABBANG CULTIVATOR)        | 76590009  | 1   |
| 19                 | HEX HEAD BOLT 12X60X1.75MM (8.8 GRADE) (30MM THREAD) | 10260356  | 4   |
| 20                 | SPRING WASHER 12MM                                   | 10270003  | 4   |
| 21                 | NYLOCK NUT M12X1.75 (P)                              | 10280025  | 4   |
| 22                 | SPLIT PIN 1/8X2.5 INCH                               | 10020097  | 1   |

SIDE DISC ASSEMBLY

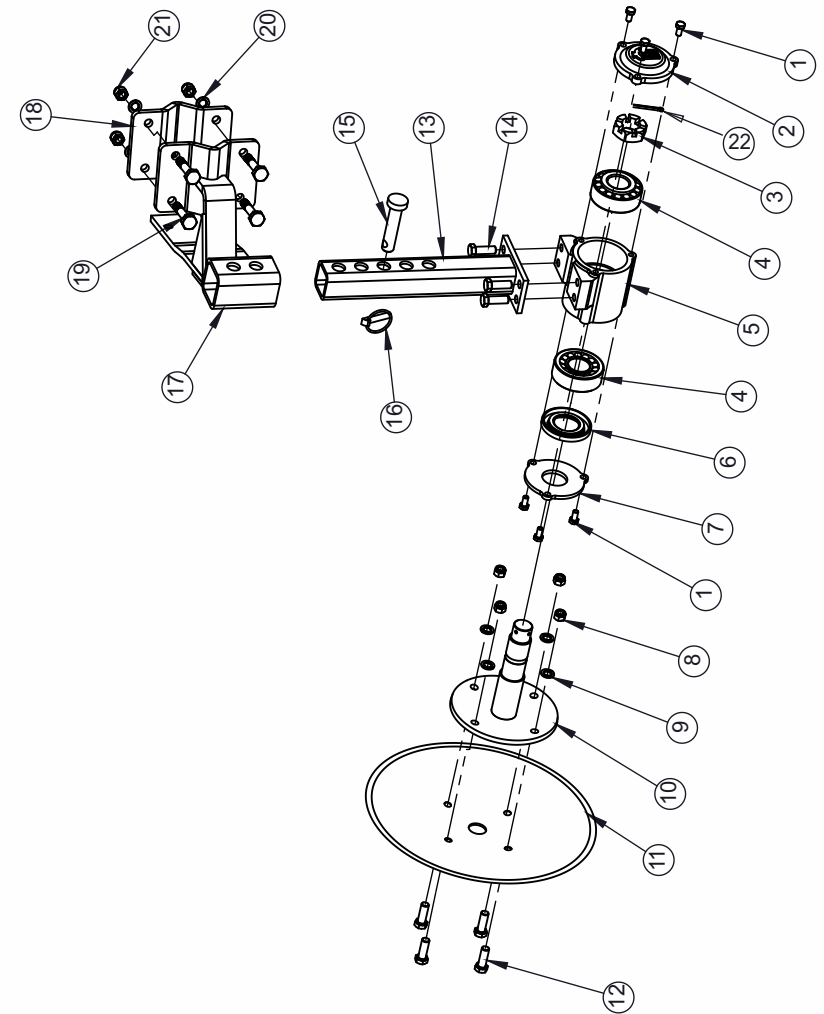

| Rotary Tiller PTO Shaft |   | Part Code |          |          |          |
|-------------------------|---|-----------|----------|----------|----------|
|                         |   | 540 RPM   |          | 1000 RPM |          |
|                         |   | CUT       | FULL     | CUT      | FULL     |
| Sr No.                  | Description   | 10310059  | 10310060 | 10310083 | 10310084 |
| 1                       | PTO PUSH PIN YOKE WITH PIN - 38.05.10B (12X10)            | 10310073  |          |          | 10310075 |
| 2                       | PTO CROSS JOURNAL SET-38.01                               |           | 10310065 |          |          |
| 3                       | PTO OUTER TUBE YOKE -38                                   |           | 10310097 |          |          |
| 4                       | DOWEL PIN 10X80 MM  |           | 10020118 |          |          |
| 5                       | INNER TUBE  | 10310039  |          |          |          |
| 6                       | OUTER TUBE  | 10310040  |          |          |          |
| 7                       | PTO INNER TUBE YOKE -38                                   |           | 10310096 |          |          |
| 8                       | PTO COMPLETE SHEAR BOLT ASSEMBLY (6SPLINE)- 38SBT (12X10) |           | 10310071 |          |          |
| 9                       | GUARD RETAINING COLLAR FOR OUTER TUBE                     | 10310011  |          |          |          |
| 10                      | GUARD RETAINING COLLAR FOR INNER TUBE                     | 10310012  |          |          |          |
| 11                      | SAFETY CHAINS   | 10310013  |          |          |          |
| 12                      | COMPLETE GUARD ASSEMBLY                                   | 10310014  | 10310047 | 10310014 | 10310047 |
| 13                      | PTO PUSH PIN SET-14X69 (Small)                            |           | 10310077 |          |          |
| 14                      | PTO PUSH PIN SET-14X91 (Big)                              |           | 10310078 |          |          |
| 15                      | YOKE FOR B02  |           | 10310030 |          |          |
| 16                      | BALL 5/16"  |           | 10310017 |          |          |
| 17                      | HUB B02   |           | 10310042 |          |          |
| 18                      | HEX HEAD BOLT M10X65X1.5MM SAFETY BOLT                    | 10260046  |          |          |          |
| 19                      | NYLOCK NUT M10X1.5MM                                      | 10280002  |          |          |          |
| 20                      | GREASE FITTING  | 10310019  |          |          |          |
| 21                      | U-JOINT FOR OUTER TUBE                                    | 10310020  |          | 10310056 |          |
| 22                      | U-JOINT FOR INNER TUBE                                    |           | 10310021 |          |          |
| 23                      | HALF FEMALE GUARD ASSY.                                   | 10310048  | 10310051 | 10310048 | 10310051 |
| 24                      | HALF MALE GUARD ASSY.                                     | 10310049  | 10310050 | 10310049 | 10310050 |

### PTO ASSEMBLY-SHEAR BOLT TYPE

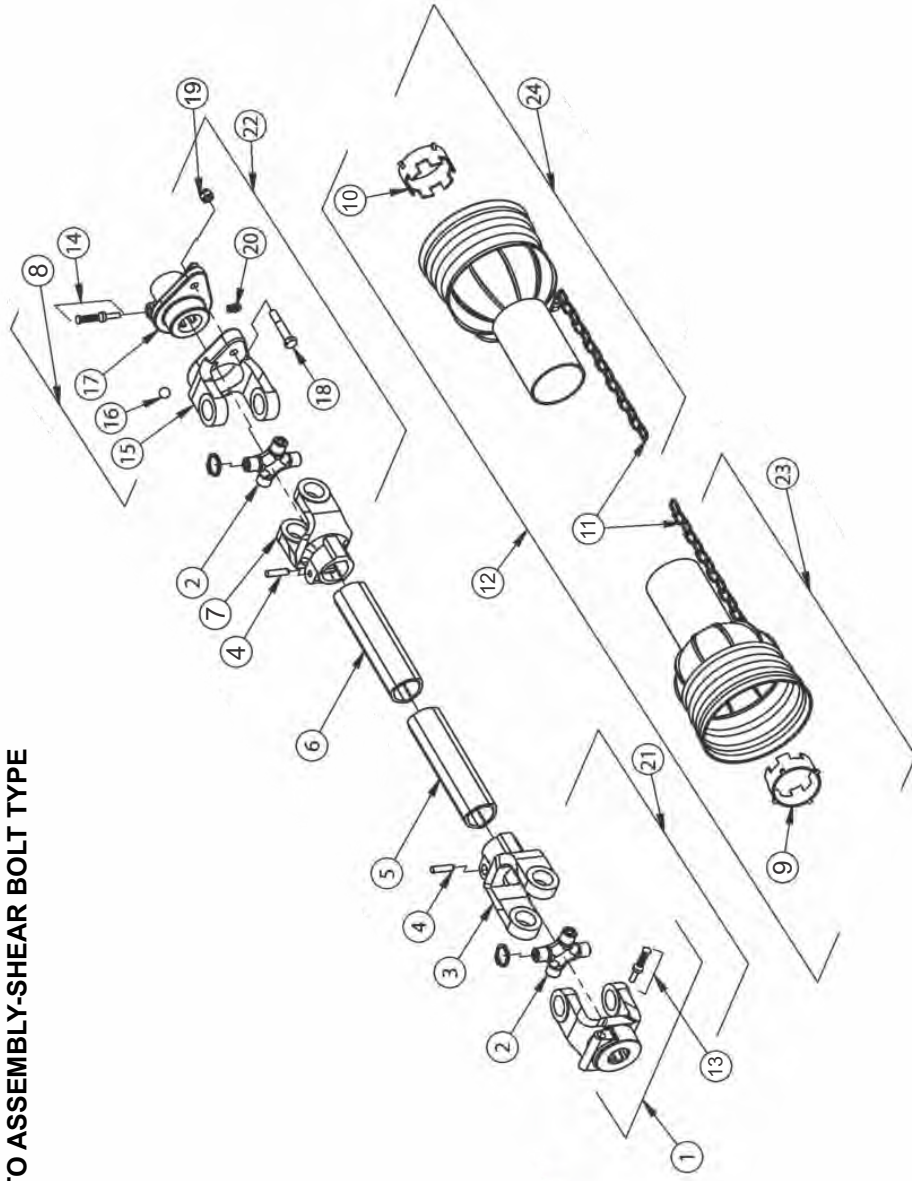



## DELIVERY CHECKLIST

| Dealer Pre-Delivery (Please Tick)   | Please Complete all Dealer information Below  |
|---|---|
| <p><b>1. Dealer Pre-Delivery Checklist</b></p> <ol style="list-style-type: none"> <li>1. The customer or person responsible has been given the operator's manual.</li> <li>2. The customer undertakes to read the complete operator's manual and understands all aspects of the manual before operation of the machine.</li> <li>3. All safety, operational and maintenance information have been explained and demonstrated.</li> <li>4. All greasing and oil points, stickers, guarding and ID plate have been identified and physically pointed out.</li> <li>5. The customer agrees that it is his responsibility to read and carry out the safety, maintenance and operation as per this operator's manual.</li> </ol> | <p><b>Dealer Information</b></p> <p>Dealer's Name.....</p> <p>Address.....</p> <p>State..... Postcode.....</p> <p>Phone..... Fax.....</p> <p>Email.....</p> <p>Service Person.....</p> <p>I confirm that the pre-delivery service was performed on this machine.</p> <p>Signature.....</p> <p>Date.....</p> <p>Comments.....</p>                |
| Customer Delivery (Please Tick)   | Please Complete all Customer Information Below  |
| <p><b>2. Customer Delivery Checklist</b></p> <ol style="list-style-type: none"> <li>1. The customer or person responsible has been given the operator's manual.</li> <li>2. The customer undertakes to read the complete operator's manual and understands all aspects of the manual before operation of the machine.</li> <li>3. All safety, operational and maintenance information have been explained and demonstrated.</li> <li>4. All greasing and oil points, stickers, guarding and ID plate have been identified and physically pointed out.</li> <li>5. The customer agrees that it is his responsibility to read and carry out the safety, maintenance and operation as per this operator's manual.</li> </ol>   | <p><b>Customer Information</b></p> <p>Customer's Name.....</p> <p>Address.....</p> <p>State..... Postcode.....</p> <p>Phone..... Fax.....</p> <p>Email.....</p> <p>Delivery Person.....</p> <p>I confirm that all of the delivery checks were explained and performed.</p> <p>Signature.....</p> <p>Delivery Date.....</p> <p>Comments.....</p> |

# FIELDKING

## WARRANTY CARD Customer Copy

CUSTOMER NAME Mr./ Mrs. :

ADDRESS :

MOBILE NO. :

Email :

NAME OF IMPLEMENT :

MODEL NO. :

YEAR OF Mfg. :

SERIAL NO. :

REGISTRATION NO. :

DATE OF PURCHASING :

NAME OF DEALER :

Customer's Signature

Dealer's Signature



**Beri Udyog Pvt. Ltd.**

**Corporate Office :** Plot No. 235-236 & 238-240, Sec-3, HSIIDC,  
Karnal- 132001 (Haryana), India

+91-184-2221571/ 72/ 73  
✉ marketing@fieldking.com, exports@fieldking.com, 🌐 www.fieldking.com

# FIELDKING

## WARRANTY CARD Company Copy

CUSTOMER NAME Mr./ Mrs :

ADDRESS :

MOBILE NO. :

Email :

NAME OF IMPLEMENT :

MODEL NO. :

YEAR OF Mfg. :

SERIAL NO. :

REGISTRATION NO. :

DATE OF PURCHASING :

NAME OF DEALER :

Customer's Signature

Dealer's Signature



**Beri Udyog Pvt. Ltd.**

**Corporate Office :** Plot No. 235-236 & 238-240, Sec-3, HSIIDC,  
Karnal- 132001 (Haryana), India ☎ +91-184-2221571/ 72/ 73

✉ marketing@fieldking.com, exports@fieldking.com, 🌐 www.fieldking.com

# FIELDKING

## WARRANTY CARD

Dealer Copy

CUSTOMER NAME Mr./ Mrs :

ADDRESS :

MOBILE NO. :

Email :

NAME OF IMPLEMENT :

MODEL NO. :

YEAR OF Mfg. :

SERIAL NO. :

REGISTRATION NO. :

DATE OF PURCHASING :

NAME OF DEALER :

Customer's Signature

Dealer's Signature



**Beri Udyog Pvt. Ltd.**

**Corporate Office** : Plot No. 235-236 & 238-240, Sec-3, HSIIDC,  
Karnal- 132001 (Haryana), India ☎ +91-184-2221571/ 72/ 73

✉ marketing@fieldking.com, exports@fieldking.com, 🌐 www.fieldking.com